

5

4

3

2

1

ZONE		REV.	REVISIONS		DATE	APPROVED
			DESCRIPTION			

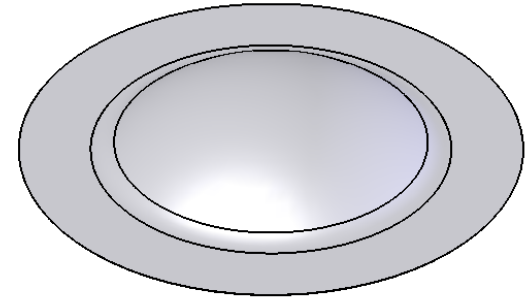
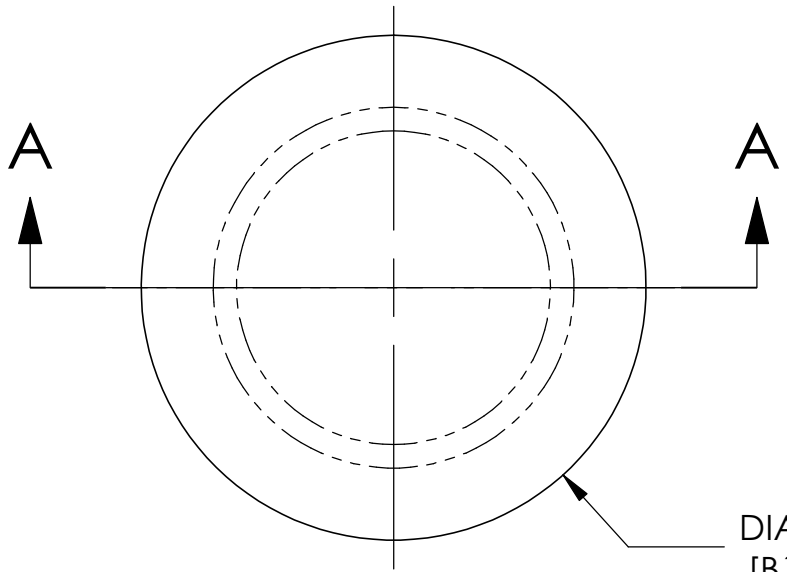

DIAMETER  
[B1]/[B2]

HEIGHT  
(REFERENCE)  
[C]

SPHERICAL RADIUS  
[A]

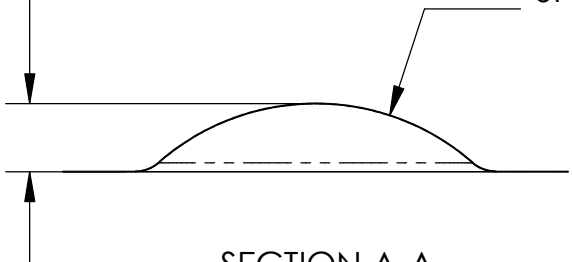

SECTION A-A

Spherical Radius [A]		Minimum Diameter [B1]		Maximum Diameter [B2]		Height (Reference) [C]	
(Inches)	(mm)	(Inches)	(mm)	(Inches)	(mm)	(Inches)	(mm)
0.687	17.4	1.135	28.8	1.750	44.5	0.232	5.9
0.710	18.0	1.063	27.0	1.250	31.8	0.220	5.6
0.809	20.5	1.250	31.8	1.500	38.1	0.237	6.0
0.809	20.5	1.090	27.7	1.500	38.1	0.181	4.6
0.828	21.0	1.353	34.4	1.500	38.1	0.236	6.0
1.105	28.1	1.100	27.9	1.100	27.9	0.078	2.0
1.105	28.1	1.300	33.0	1.750	44.5	0.178	4.5
2.138	54.3	3.228	82.0	4.750	120.7	0.624	15.8
2.192	55.7	3.590	91.2	3.625	92.1	0.796	20.2
2.242	56.9	3.642	92.5	3.750	95.3	0.864	21.9
3.030	77.0	3.175	80.6	3.250	82.6	0.402	10.2

NOTES:  
 1. DRAWING IS FOR REFERENCE OF AVAILABLE TOOLING ONLY.  
 2. FOR QUOTE INQUIRIES PLEASE SPECIFY DOME SPHERICAL RADIUS & OUTER DIAMETER.

Interpret Drawing per ANSI Y14.5 M-1994 Unless otherwise specified.	DRAWN		NAME	DATE	<b>BRUSH WELLMAN</b> <b>ELECTROFUSION PRODUCTS</b> TITLE: <p style="text-align: center;">DOME WITH SURROUND</p>		
	ENG APPR.		B. LOWE	2/14/07			
	UNLESS OTHERWISE SPECIFIED: DIMENSIONS ARE IN Inch [mm]		CUSTOMER		SIZE	DWG. NO.	REV
	TOLERANCES: ANGLES ±0.5 .X ±0.03 [0.8] .XX ±0.005 [0.13]		MATERIAL		<b>A</b>	A-XXXXXXXX-20	-
FINISH			Be/AlBeMet		SCALE: 3:2	DO NOT SCALE DRAWING	SHEET 1 OF 1

5

4

3

2

1